

— NOTICE —
 This drawing is a part of the proprietary article therein disclosed, and all design, manufacturing, reproduction, use, patent rights, and other rights regarding the same are expressly reserved by Aero Space Controls Corporation, Wichita, Kansas. It is admitted under a confidential relationship for a specific purpose and shall not be disclosed to any unauthorized person or incorporated in any other projects.

REVISIONS				
C.O. NO.	REV.	REVISION DESCRIPTION	DATE	APPD.
ASC4739	E	SEE SHEET 1 FOR REVISIONS	2-8-10	D.S.

PERFORMANCE CHART

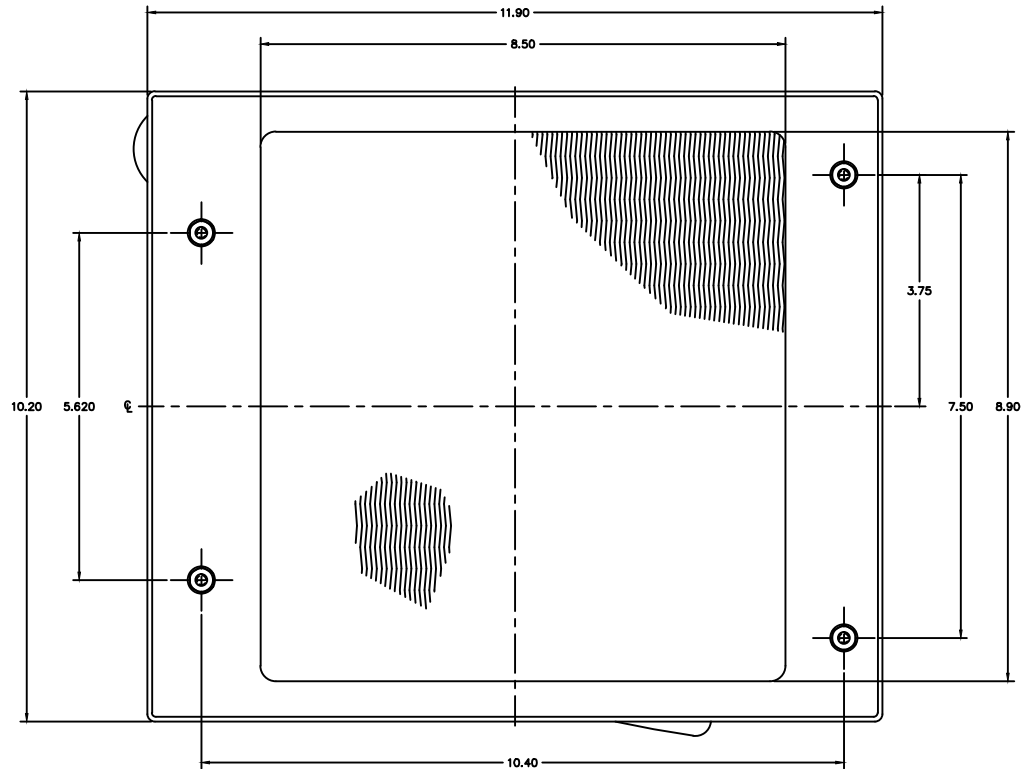
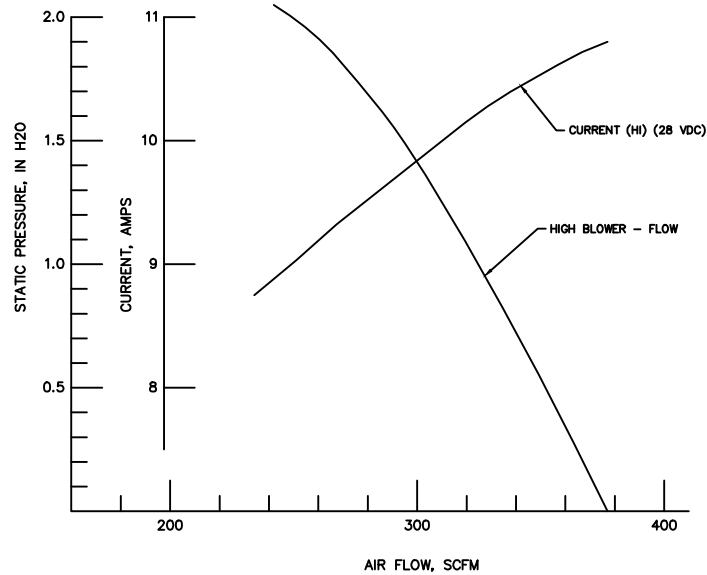

LEFT END VIEW

- NOTES CONTINUED:
- MODULE CAPACITY:
 - 12,000 BTUH AT 300 CFM 80°F INLET AIR
180 PSIG 100°F INLET FREON
38 PSIG OUTLET FREON
 - 16,000 BTUH AT 325 CFM 103°F INLET AIR
200 PSIG 110°F INLET FREON
38 PSIG OUTLET FREON
 - BLOWER CAPACITY: TWO SPEED, 350 CFM AT 0.5 IN H₂O BACKPRESSURE ON HIGH SPEED.
LOW SPEED IS APPROXIMATELY 50% OF HIGH SPEED.
 - ELECTRICAL POWER: 27 VDC, 200 WATTS
 - MODULE WEIGHT: 12 LBS. MAXIMUM
 - BLOWER SCROLL OUTLET AND FREON INLET LOCATION ORIENTATION OPTIONAL
 - EXPANSION VALVE ADJUSTABLE. SAME PRESET AT 38 PSIG.
 - LIQUID DRAIN TO BE LOCATED AT EITHER LOW POINTS AS INDICATED.
POSITION MUST NOT INTERFERE WITH SCROLL.
 - SEE SHEET (1)

QTY.	ITEM	SIZE	PART NUMBER	DESCRIPTION	MATERIAL	MAT'L. SPEC.	FINISH	FINISH SPEC.
LIST OF MATERIALS								
DIMENSIONAL SYMBOLS PER ASME Y14.5				UNLESS OTHERWISE SPECIFIED		SIGNATURES		DATE
▧ FLATNESS — STRAIGHTNESS ∠ ANGULARITY ⊥ PERPENDICULARITY // PARALLELISM ⊙ CONCENTRICITY ⊕ TRUE POSITION ○ CIRCULARITY (ROUNDNESS) = SYMMETRY (M) (MMC) MAXIMUM MATERIAL CONDITION (RFS) REGARDLESS OF FEATURE SIZE				1. DIMENSIONS ARE IN INCHES — TOLERANCES ON — FRACTIONS ± 1/16 ANGLES ± 0° 30' XX DEC ±.030 DRILL HOLES AND 10387 2. SURFACE ROUGHNESS PER ASME-B46.1 3. REMOVE BURRS & BREAK SHARP EDGES .010 MAX. 4. INTERNAL RADII .005 TO .015 5. STRAIGHT SCREW MIL-S-7742 TAPERED PIPE MIL-P-7105		DR. Daniel Simor CHK. ENGR. APPD. DON SIMON NEXT ASSY:		6-3-03
AERO SPACE CONTROLS CORPORATION WICHITA, KANSAS						TITLE:		
						EVAPORATOR MODULE		
6. ALL DIMENSIONS BEFORE PLATING						CODE IDENT No.	SIZE	DWG. No.
						DO NOT SCALE DRAWING		D
SCALE: 1:1						UNIT WT.	LBS.	SHT. 2 OF 3

— NOTICE —
 This drawing is a part of the proprietary article therein disclosed, and all design, manufacturing, reproduction, use, patent rights, and other rights regarding the same are expressly reserved by Aero Space Controls Corporation, Wichita, Kansas. It is admitted under a confidential relationship for a specific purpose and shall not be disclosed to any unauthorized person or incorporated in any other projects.

REVISIONS				
C.O. NO.	REV.	REVISION DESCRIPTION	DATE	APPD.
ASC4739	E	SEE SHEET 1 FOR REVISIONS	2-8-10	D.S.

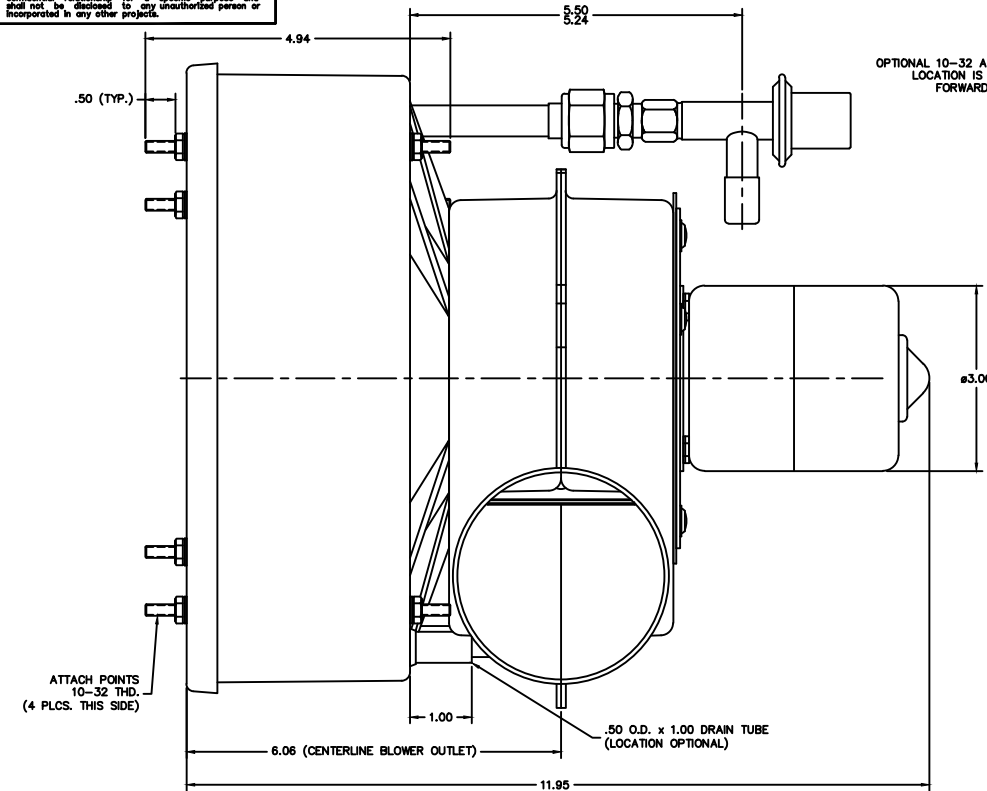

OPTIONAL 10-32 ATTACH POINTS
 LOCATION IS THE SAME ON
 FORWARD OR AFT SIDE

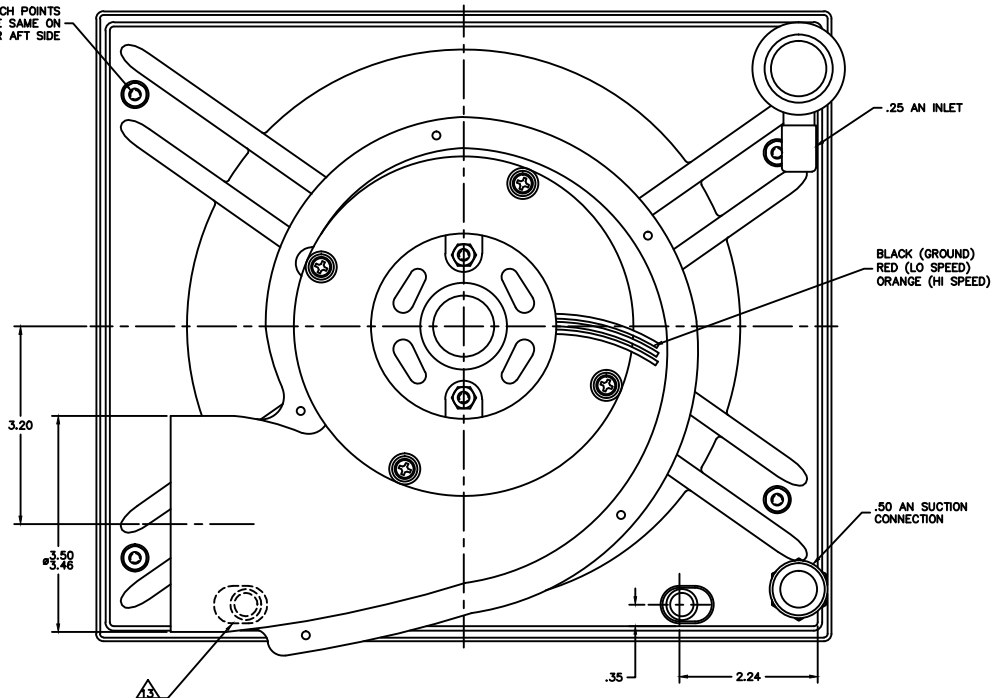

RIGHT END VIEW

SIDE VIEW

1523300-10A1 CONFIGURATION SHOWN

- NOTES CONTINUED:
- MODULE CAPACITY:
 - 12,000 BTUH AT 300 CFM 80°F INLET AIR
180 PSIG 100°F INLET FREON
38 PSIG OUTLET FREON
 - 16,000 BTUH AT 325 CFM 103°F INLET AIR
200 PSIG 110°F INLET FREON
38 PSIG OUTLET FREON
 - BLOWER CAPACITY: TWO SPEED, 350 CFM AT 0.5 IN H₂O BACKPRESSURE ON HIGH SPEED.
LOW SPEED IS APPROXIMATELY 50% OF HIGH SPEED.
 - ELECTRICAL POWER: 27 VDC, 200 WATTS
 - MODULE WEIGHT: 12 LBS. MAXIMUM
 - BLOWER SCROLL OUTLET AND FREON INLET LOCATION ORIENTATION OPTIONAL
 - EXPANSION VALVE ADJUSTABLE. SAME PRESET AT 38 PSIG.
 - LIQUID DRAIN TO BE LOCATED AT EITHER LOW POINTS AS INDICATED.
POSITION MUST NOT INTERFERE WITH SCROLL.
 - SEE SHEET (1)

QTY.	ITEM	SIZE	PART NUMBER	DESCRIPTION	MATERIAL	MAT'L. SPEC.	FINISH	FINISH SPEC.
LIST OF MATERIALS								
DIMENSIONAL SYMBOLS PER ASME: Y14.5				UNLESS OTHERWISE SPECIFIED		SIGNATURES		DATE
▽ FLATNESS — STRAIGHTNESS ∠ ANGULARITY ⊥ PERPENDICULARITY // PARALLELISM ⊙ CONCENTRICITY ⊕ TRUE POSITION ○ CIRCULARITY (ROUNDNESS) = SYMMETRY (M) (MMC) MAXIMUM MATERIAL CONDITION (S) (RFS) REGARDLESS OF FEATURE SIZE				1. DIMENSIONS ARE IN INCHES — TOLERANCES ON — FRACTIONS ± 1/16 ANGLES ± 0° 30' XX DEC ±.030 DRILL HOLES AND 10387 XXX DEC ±.010		DR. Daniel Simon CHK. ENGR.		6-3-03
				2. SURFACE ROUGHNESS PER ASME-B46.1		APPD. DON SIMON NEXT ASSY:		6-4-03
				3. REMOVE BURRS & BREAK SHARP EDGES .010 MAX.		6. ALL DIMENSIONS BEFORE PLATING		
				4. INTERNAL RADII .005 TO .015		DO NOT SCALE DRAWING		
				5. STRAIGHT SCREW MIL-S-7742 TAPERED PIPE MIL-P-7105				
AERO SPACE CONTROLS CORPORATION WICHITA, KANSAS						TITLE: EVAPORATOR MODULE		
						CODE IDENT No.	SIZE	DWG. No.
							D	1523300
						SCALE: 1:1	UNIT WT.	LBS.
						SHT. 3 OF 3		