

- NOTICE -

This drawing is a part of the proprietary article therein disclosed, and all design, manufacturing, reproduction, use, patent rights, and sales rights regarding the same are expressly reserved by Aero Space Controls Corporation, Wichita, Kansas. It is submitted under a confidential relationship for a specific purpose and shall not be disclosed to any unauthorized person or incorporated in any other projects.

REVISIONS				
C.O. NO.	REV.	REVISION DESCRIPTION	DATE	APPD.
ASC2775	J	SEE SHEET 1 FOR REVISIONS	3-5-04	D.S.

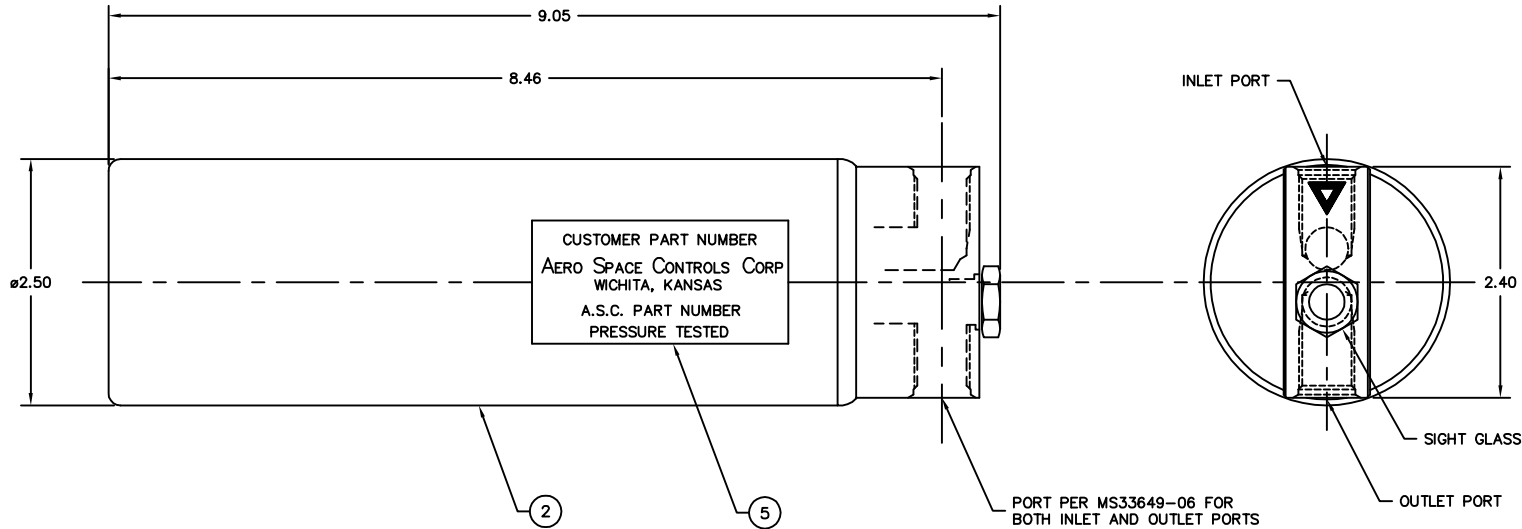

-3 CONFIGURATION

NOTES CONTINUED:

7. THE PURPOSE OF THE RECEIVER-DRYER IS TO:
 - STORE HIGH PRESSURE LIQUID REFRIGERANT FROM THE CONDENSER COIL
 - FILTER OR SCREEN THE REFRIGERANT TO PREVENT SCALE OR DIRT FROM REACHING THE EXPANSION VALVE
 - DRY OR ABSORB MOISTURE WITH A DESICCANT SUCH AS XH-7
 - PROVIDE A SIGHT GLASS TO VISUALLY DETERMINE IF ADEQUATE REFRIGERANT IS IN THE SYSTEM.
8. THE UNIT SHALL BE COMPATIBLE WITH REFRIGERANT R-12 AND 134a
9. RELIABILITY: THE SERVICE LIFE SHALL NOT BE LESS THAN 10,000 HOURS IN NORMAL AIRCRAFT USAGE WITH NO OVERHAUL REQUIRED.
10. THE UNIT MUST WITHSTAND 500 PSI INTERNAL PRESSURE - NO LEAKAGE - 1000 PSI BURST PRESSURE.
11. AMBIENT TEMPERATURE -65°F TO 165°F. OPERATIONAL TEMPERATURE 300°F MAXIMUM
12. THE UNIT SHALL BE CAPABLE OF WITHSTANDING IN-FLIGHT OPERATIONAL LOADS OF 9 G's IN ANY DIRECTION WITHOUT FAILURE.
13. THE UNIT MUST BE CLEAN AND FREE FROM FOREIGN MATERIAL, DRIED AND SEALED FOR SHIPMENT.
14. FINISH: WHITE ENAMEL, KAEPOX #63W9

QTY		ITEM	SIZE	PART NUMBER	DESCRIPTION	MATERIAL	MATL SPEC	FINISH	FINISH SPEC
-3									
LIST OF MATERIALS									
DIMENSIONAL SYMBOLS PER MIL-STD-88		UNLESS OTHERWISE SPECIFIED		SIGNATURES		DATE		AERO SPACE CONTROLS CORPORATION WICHITA, KANSAS	
∩	FLATNESS & STRAIGHTNESS	1. DIMENSIONS ARE IN INCHES TOLERANCES ON		DR	D. SIMON	8-14-91		TITLE	
∠	ANGULARITY	FRACTIONS ± 1/16		CHK				RECEIVER DRYER AIR CONDITIONER	
J	PERPENDICULARITY	XX DEC ±.030		ENGR				CODE IDENT NO. SIZE DWG NO.	
	PARALLELISM	XXX DEC ±.010		APPR				C 1523258	
⊙	CONCENTRICITY	2. SURFACE ROUGHNESS PER MIL-STD-10		NEXT				SCALE 1:1 UNIT WT LBS SHT 2 OF 2	
⊕	TRUE POSITION	3. REMOVE BURRS & BREAK SHARP EDGES .010 MAX		ASSY					
⊖	ROUNDNESS	4. INTERNAL RADII .005 TO .015		6. ALL DIMENSIONS BEFORE PLATING					
⊘	SYMMETRY	5. STRAIGHT SCREW MIL-S-7742 TAPERED PIPE MIL-P-7105							
⊗	MAXIMUM MATERIAL CONDITION	THREADS							
⊗	REGARDLESS OF FEATURE SIZE	DO NOT SCALE DRAWING							
A.S.C. P/N		CUST. P/N		APPLICATION					